

ERDOĞANLAR OTOMOTİV

PRECISION TURNED PARTS & BENDING & WELDING & FORGING & MACHINING



Content



-
- **Company overview**
 - Machinery
 - Quality
 - Products and technical skills
 - Contact Information
-



Profile



- Our company was established in 1984,
- 1.600 m² factory area in Istanbul,
- 35 employees with an average experience of 12 years,
- Several local and European customers,
- Growing export figures in total revenue,
- 0,2 mio. € investment within one year,
- Manufacturing all kinds of steel, stainless steel, brass, aluminum metal bars, rods and tubes



Facts & Figures



Erdoğanlar revenues
€ million

Net Sales in million EUR

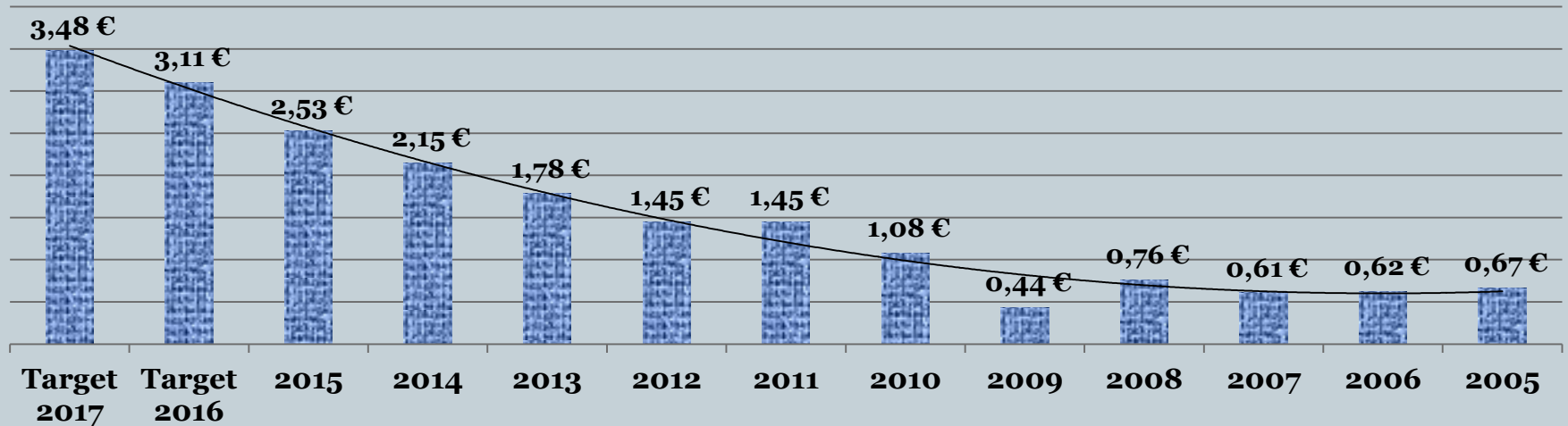

Focus areas : Automotive, Agriculture, Railways, Machinery, Electrics & Electronics, Gas components

Breakdown of Revenues



Breakdown of revenues by company in 2015

% (2015)

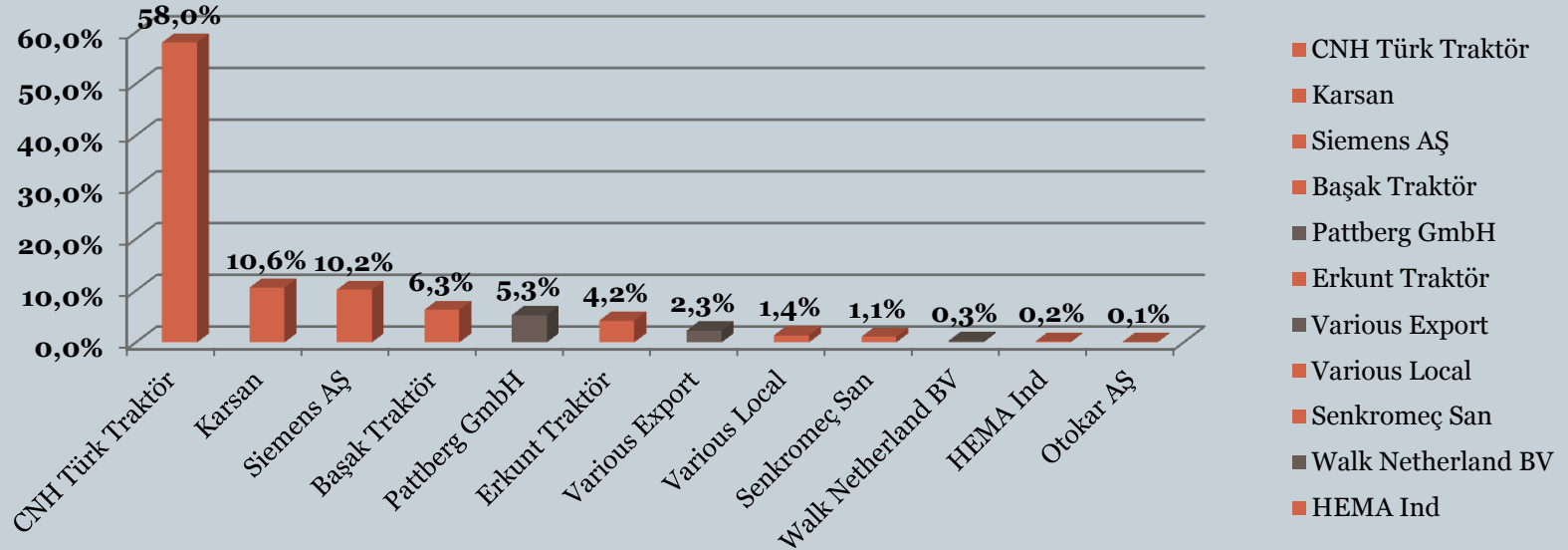

Machinery

- **CNC VERTICAL MACHINING CENTERS**



- **Doosan NM510 Vertical Machining Center-S.Korea**



- **Doosan VC430 Vertical Machining Center- S.Korea**

5 Star 3030/500/6040 CNC DRILLING AND TAPPING CENTER

- HIGH SPEED SPINDLE
- HIGH RESPONSE SERVO SYSTEM
- HIGH SPEED / AXEL NAME TRANSDUCER
- DIRECT COUPLED SPINDLE DRIVE SYSTEM
- FULL TRAVEL COLUMN, DOUBLE BEAM (STAB) & HEAVY ROSS MACHINE STRUCTURE

A NEW GENERATION OF DRILLING & TAPPING CENTER

Spindle Speed
2100-15000rpm / 15000 rpm (DTP)
RTAB: 8000 rpm / 32000 rpm (DTP)

Number of Tools
8TAB: 12 (S, H, S, H) / 24 (S, S, H, H)
9TAB: 24 (S, S, S, H)

Positioning Accuracy
JS: 0.010 / 0.005 / 0.010 mm
VD: 0.041 P: 0.010 mm

Repeatability Accuracy
JS: 0.010 / 0.005 mm
VD: 0.041 P: 0.010 mm

Rapid Tapping
8TAB: 4000 rpm
9TAB: 3000 rpm

FULL TRAVEL COLUMN STRUCTURE

- **TWIN PLATES Ares Seiki S6040 –Taiwan**



Machinery

- CNC TURNING LATHE with twin spindles and Y AXIS
Takisawa- TS 4000 YS Japan



- CNC TURNING LATHE with C AXIS Doosan Puma280M
Lathe-S.Korea



- CNC B42 BENDING MACHINE



- CNC TAKISAWA TC 20R TURNING CENTER

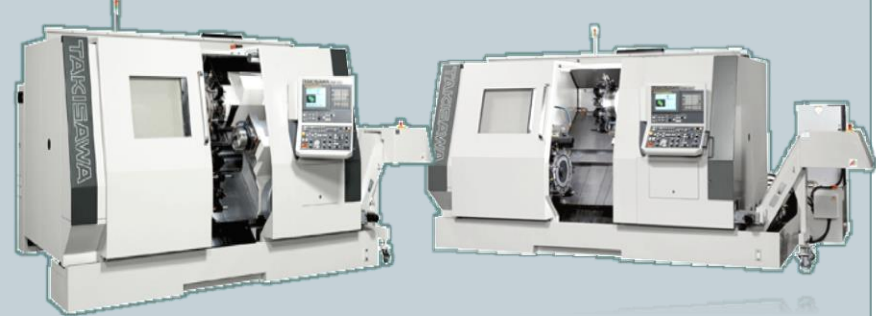

Machinery



- **PRODUCTION**

- 9 CNC Turning Lathe
- 5 CNC Vertical Machining Center
- 1 CNC B42 Bending Machine
- 1 Universal Turning Lathe
- 3 Universal Milling Machine
- 3 Grinding Machines
- 1 Friction Press
- 1 Hydrolic Press
- 1 Egzantric Press
- 3 Sawing Machine

- **WELDING & QUALITY CONTROL**

- 2 MIG Welding Machine
- 1 Argon Welding Machine
- 1 Oxygen Welding Machine
- 1 Air Compressor
- 3D CNC COORDINATE MEASUREMENT
- MicroVickers Hardness tester 0,05 kg-2,00 kg
- SURFACE ROUGHNESS
- HORIZONTAL OPTICAL COMPARATOR
- Coating Thickness Tester
- Height Measuring Station-Mitutoyo LH600E
- VISION MICROSCOPE +



Quality System



ISO 9001-2008 certificate

Methods;

- PPAP
- 6 Sigma
- SPC
- MSA
- FMEA
- 8D
- Process Analysis
- Kaizen
- FIFO

Audit Results;

- Siemens 81% VDA6.3
- 08/01/2015
- CNH TTF; 78,2% PSA
- 29/12/2011



Quality Control



3 Boyutlu Ölçüm Cihazı & 2 Boyutlu Ölçüm Cihazı 3D CMM & 2D MEASUREMENTS EQUIPMENTS

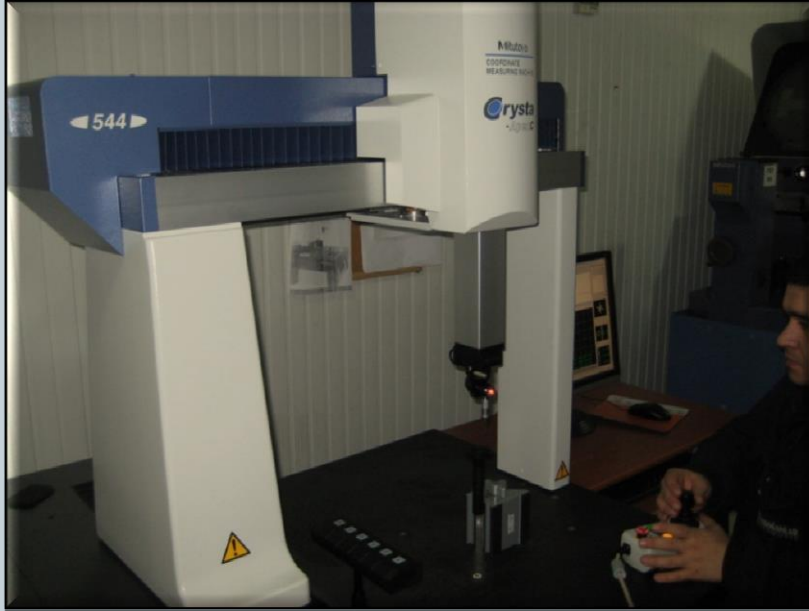

Quality Control



Metalografi Kontrol Ekipmanları METALOGRAFIC CONTROL EQUIPMENTS



Products



Precision Turning Parts – Fein Spanende Fertigungsprodukte



Precision Bearing Parts – Feine Auflagerung Produkte



Complex Welding Products – Komplizierte Schweissarbeiten



Special bolts & nuts



Hot & Cold forging products



Products



Products

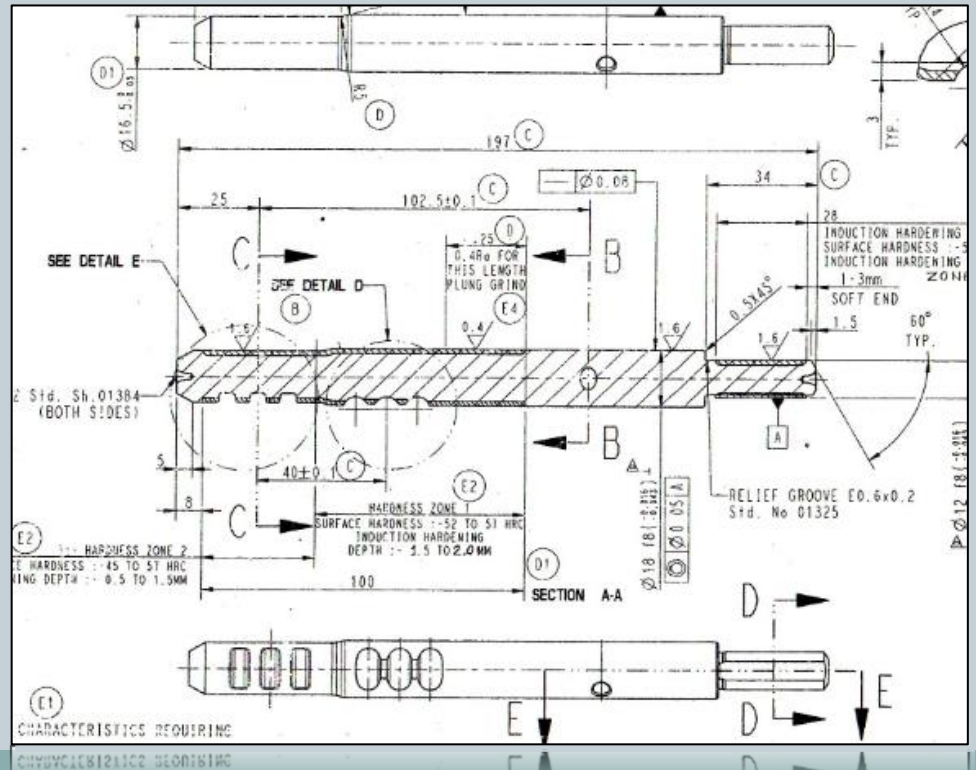
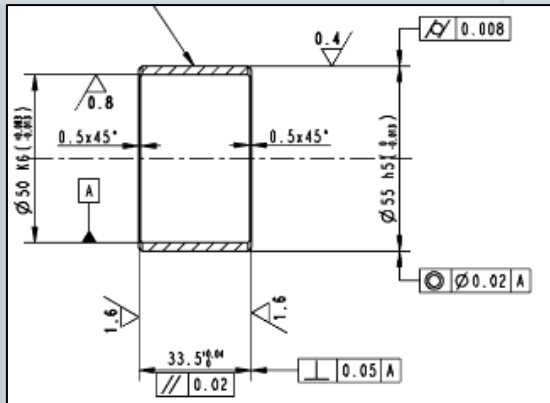
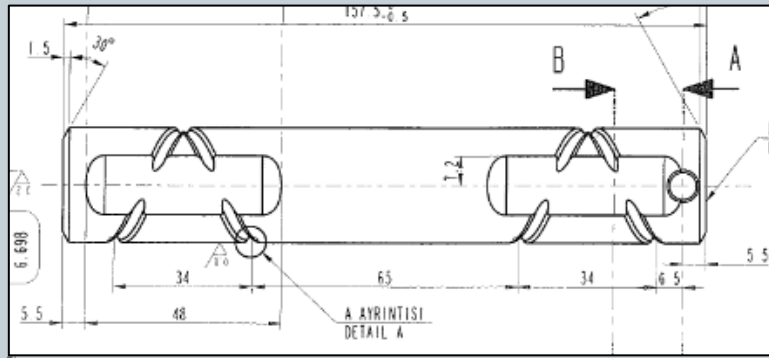

Packaging



- with VCI paper, protect oil, plastic netting with barcode system exc.



Views from our production site





Contact



ERDOĞANLAR OTOMOTİV YOL KROKİSİ

ERDOĞANLAR OTOMOTİV MAK. SAN. TİC. LTD. ŞTİ.
ADRES: RAMAZANOĞLU MAH. KAYNARCA CAD. ERKAYA SOK. NO:6
34906 KURTKÖY-PENDİK / İSTANBUL
TEL: 0216 3784835 - 4838
FAKS: 0216 3784849
PENDİK VD-3510255153
info@erdoganlarotomotiv.com

ÖLÜZ ERDOĞAN - 533 770 6978
SÜLEYMAN ERDOĞAN- 533 7706972

Eski Sokak Adı: Can
Yeni Sokak Adı: Erkaya

Google Map ya da
Navigasyon da genellikle
Can sokak olarak bulunmaktadır.

<https://www.google.com/maps/dir//40.8986166,29.2883461/@40.8985476,29.2882616,19z>

ERDOĞANLAR OTOMOTİV MAK. SAN. TİC. LTD. ŞTİ.

Address: Ramazanoğlu mah.
Kaynarca cad. Erkaya sok. No:6
34906 Kurtköy-Pendik /
İstanbul

Tel: 0216 3784835 - 4838

Fax: 0216 3784849

Vat: PENDİK - 3510255153

info@erdoganlarotomotiv.com

